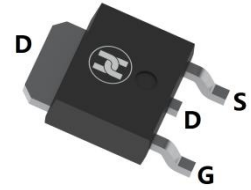
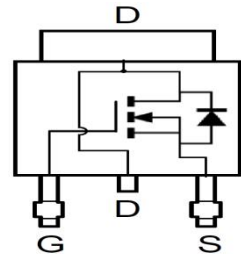

N-CHANNEL HIGH VOLTAGE MOSFET
FEATURES

- $R_{DS(ON)} = 1.0\Omega @V_{GS} = 10 V$
 $R_{DS(ON)} = 1.2\Omega @V_{GS} = 10 V$
- Ultra Low Gate Charge (Typical 29 nC)
- Low Reverse Transfer Capacitance ($C_{RSS} =$ typical 16pF)
- Fast Switching Capability
- Avalanche Energy Tested
- Improved dv/dt Capability, High Ruggedness

TO-252
MECHANICAL DATA

- Case: TO-252
- Case Material: Molded Plastic. UL flammability
- Classification Rating: 94V-0
- Weight: 0.33 grams (approximate)

MAXIMUM RATINGS (T_A = 25°C unless otherwise noted)

PARAMETER		SYMBOL	RATINGS	UNIT
Drain-Source Voltage	7N60	V _{DSS}	600	V
	7N65		650	V
Gate-Source Voltage		V _{GSS}	±30	V
Avalanche Current (Note 2)		I _{AR}	7.0	A
Drain Current	Continuous	I _D	7.0	A
	Pulsed (Note 2)	I _{DM}	29.6	A
Avalanche Energy	Single Pulsed (Note 3)	E _{AS}	530	mJ
	Repetitive (Note 2)	E _{AR}	14.2	mJ
Peak Diode Recovery dv/dt (Note 4)		dv/dt	4.5	V/ns
Power Dissipation (T _C = 25°C)		P _D	142	W
Junction Temperature		T _J	+150	°C
Ambient Operating Temperature		T _{OPR}	-55 ~ +150	°C
Storage Temperature		T _{STG}	-55 ~ +150	°C
Junction to Ambient		θ _{JA}	160	°C/W
Junction to Case		θ _{JC}	2.5	°C/W

Notes: 1. Absolute maximum ratings are those values beyond which the device could be permanently damaged.

Absolute maximum ratings are stress ratings only and functional device operation is not implied.

2. Repetitive Rating : Pulse width limited by T_J

3. L=64mH, I_{AS}=7.0A, V_{DD}=50V, R_G=25 Ω, Starting T_J = 25°C

4. I_{SD}≤7.0A, di/dt≤200A/μs, V_{DD} ≤ BV_{DSS}, Starting T_J = 25°C

N-CHANNEL HIGH VOLTAGE MOSFET
ELECTRICAL CHARACTERISTICS (T_A = 25°C unless otherwise specified)

PARAMETER	SYMBOL	TEST CONDITIONS	MIN	TYP	MAX	UNIT
OFF CHARACTERISTICS						
Drain-Source Breakdown Voltage	7N60	V _{GS} = 0V, I _D = 250μA	600			V
	7N65		650			V
Drain-Source Leakage Current	I _{DSS}	V _{DS} = 600V, V _{GS} = 0V			1	μA
Gate-Source Leakage Current	Forward	V _{GS} = 30V, V _{DS} = 0V			100	nA
	Reverse	V _{GS} = -30V, V _{DS} = 0V			-100	nA
Breakdown Voltage Temperature Coefficient	ΔBV _{DSS} /ΔT _J	I _D = 250 μA, Referenced to 25°C		0.67		V/°C
ON CHARACTERISTICS						
Gate Threshold Voltage	V _{GS(TH)}	V _{DS} = V _{GS} , I _D = 250μA	2.0		4.0	V
Static Drain-Source On-State Resistance	R _{DS(ON)}	V _{GS} = 10V, I _D = 3.51A			1.2	Ω
DYNAMIC CHARACTERISTICS						
Input Capacitance	C _{ISS}	V _{DS} = 25V, V _{GS} = 0V, f = 1MHz			1400	pF
Output Capacitance	C _{OSS}				180	pF
Reverse Transfer Capacitance	C _{RSS}			16	21	pF
SWITCHING CHARACTERISTICS						
Turn-On Delay Time	t _{D(ON)}	V _{DD} = 300V, I _D = 7.0A, R _G = 25Ω (Note 1, 2)			70	ns
Turn-On Rise Time	t _R				170	ns
Turn-Off Delay Time	t _{D(OFF)}				140	ns
Turn-Off Fall Time	t _F				130	ns
Total Gate Charge	Q _G	V _{DS} = 480V, V _{GS} = 10V, I _D = 7.0A (Note 1, 2)		29	38	nC
Gate-Source Charge	Q _{GS}			7		nC
Gate-Drain Charge	Q _{GD}			14.5		nC
DRAIN-SOURCE DIODE CHARACTERISTICS						
Drain-Source Diode Forward Voltage	V _{SD}	V _{GS} = 0 V, I _{SD} = 7.0 A			1.4	V
Continuous Drain-Source Current	I _{SD}				7.0	A
Pulsed Drain-Source Current	I _{SM}				29.6	A
Reverse Recovery Time	t _{RR}	V _{GS} = 0 V, I _{SD} = 7.0A,		320		ns
Reverse Recovery Charge	Q _{RR}	di/dt = 100 A/μs (Note1)		2.4		μC

Notes: 1. Pulse Test: Pulse width ≤ 300μs, Duty cycle ≤ 2%
2. Essentially independent of operating temperature

N-CHANNEL HIGH VOLTAGE MOSFET

Test Circuits And Waveforms

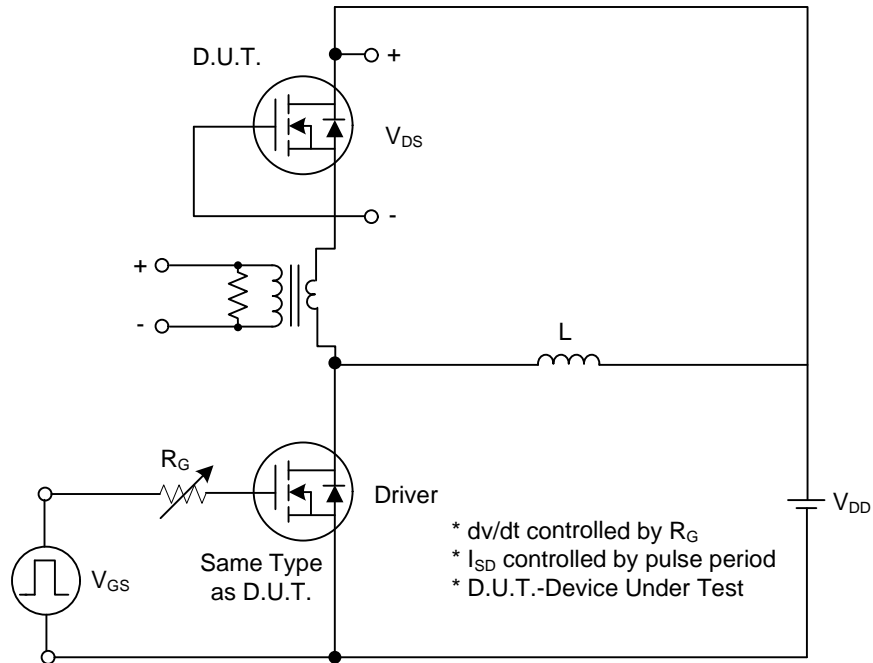

Fig. 1A Peak Diode Recovery dv/dt Test Circuit

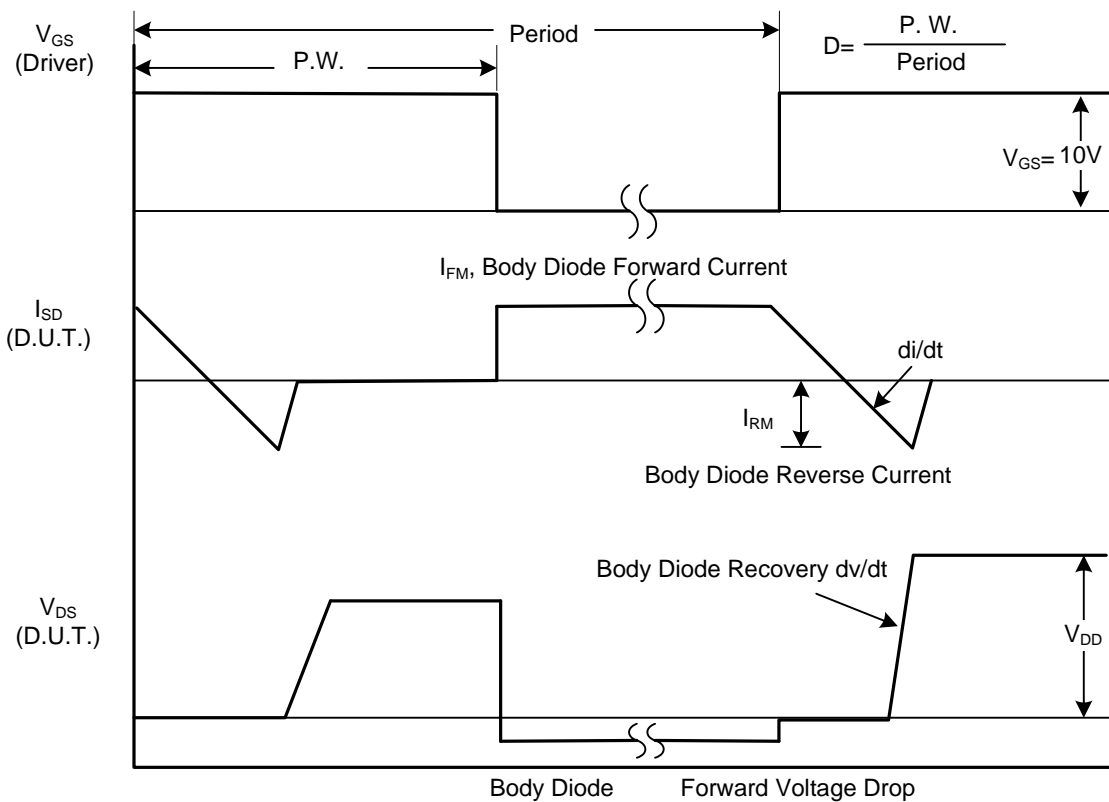

Fig. 1B Peak Diode Recovery dv/dt Waveforms

N-CHANNEL HIGH VOLTAGE MOSFET

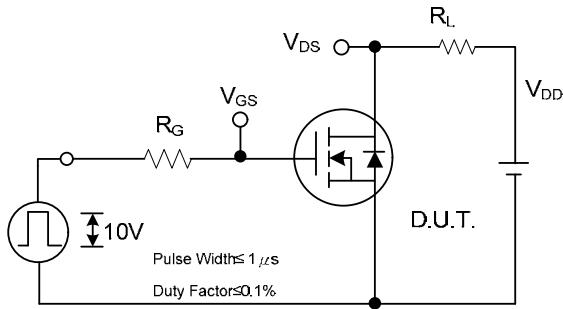

Fig. 2A Switching Test Circuit

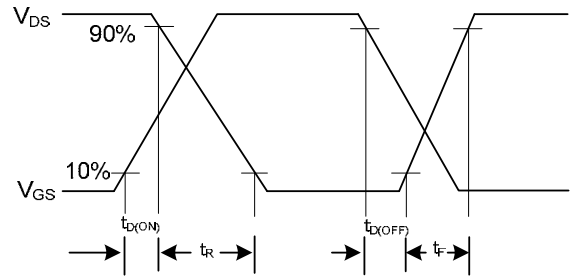

Fig. 2B Switching Waveforms

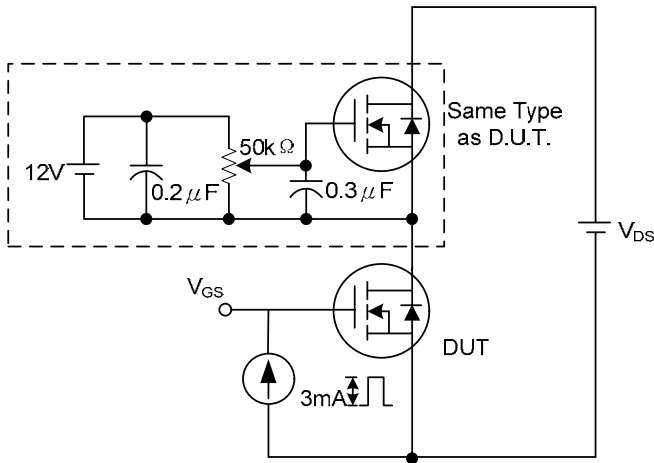

Fig. 3A Gate Charge Test Circuit

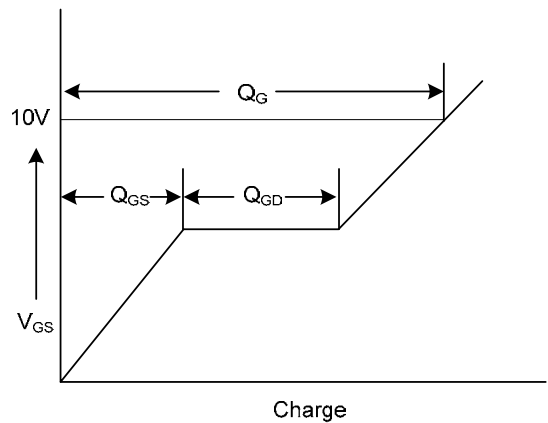

Fig. 3B Gate Charge Waveform

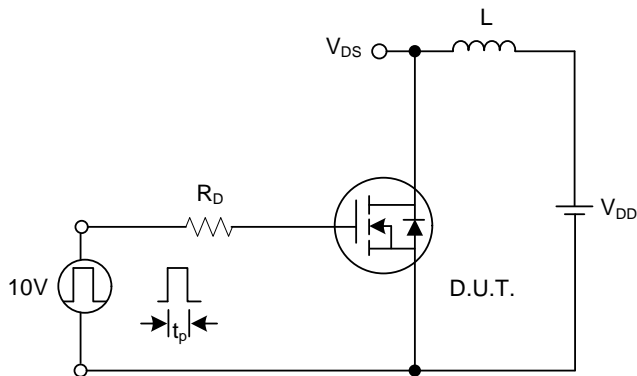

Fig. 4A Unclamped Inductive Switching Test Circuit

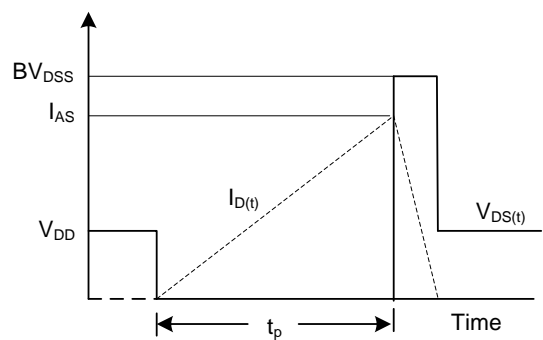
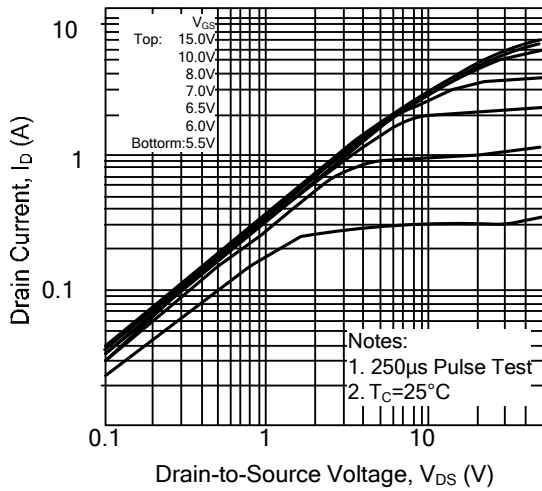

Fig. 4B Unclamped Inductive Switching Waveforms

N-CHANNEL HIGH VOLTAGE MOSFET

Typical Characteristics

On-State Characteristics



Transfer Characteristics

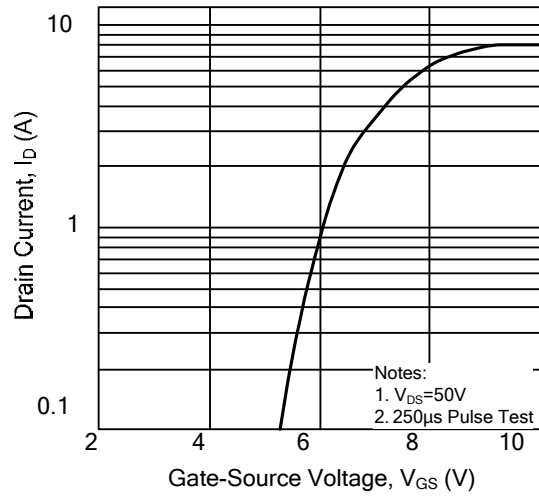

On-Resistance Variation vs. Drain Current and Gate Voltage

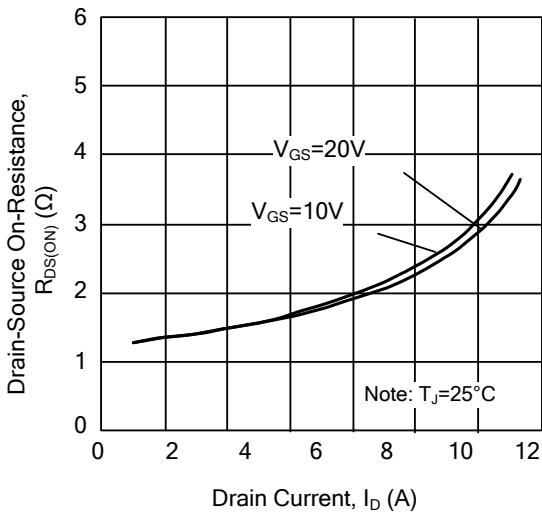

On State Current vs. Allowable Case Temperature

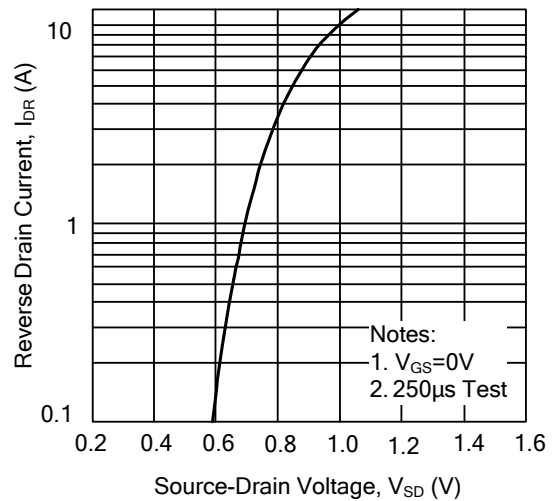

Capacitance Characteristics (Non-Repetitive)

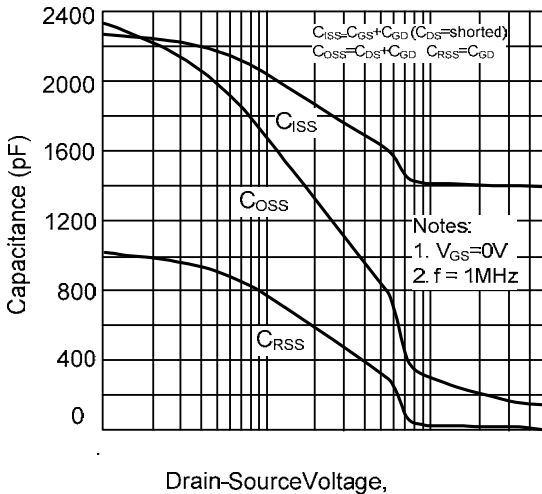

Gate Charge Characteristics

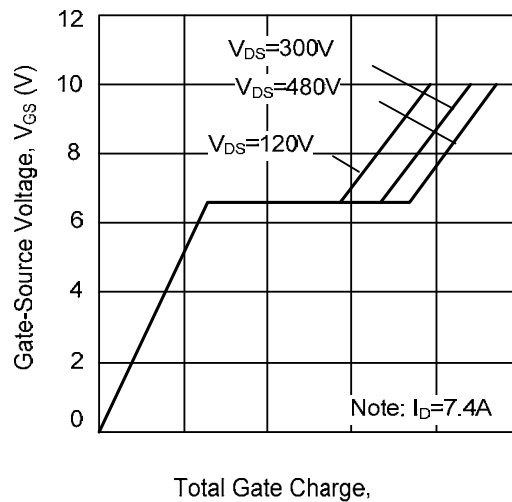

N-CHANNEL HIGH VOLTAGE MOSFET

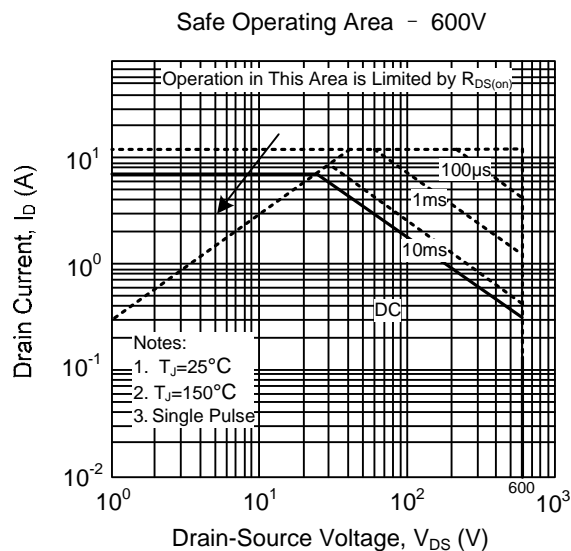
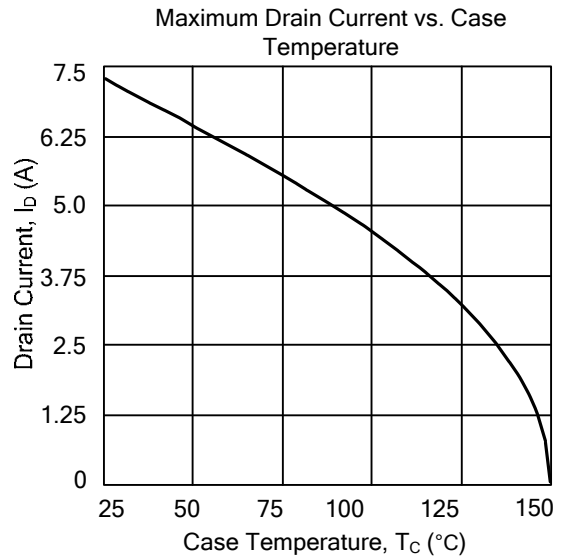
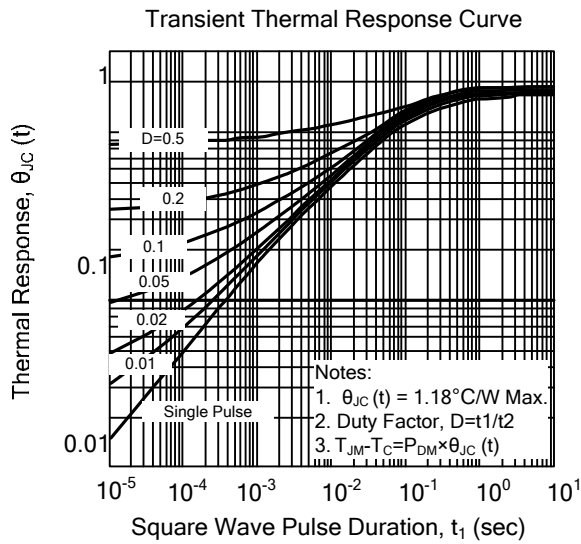
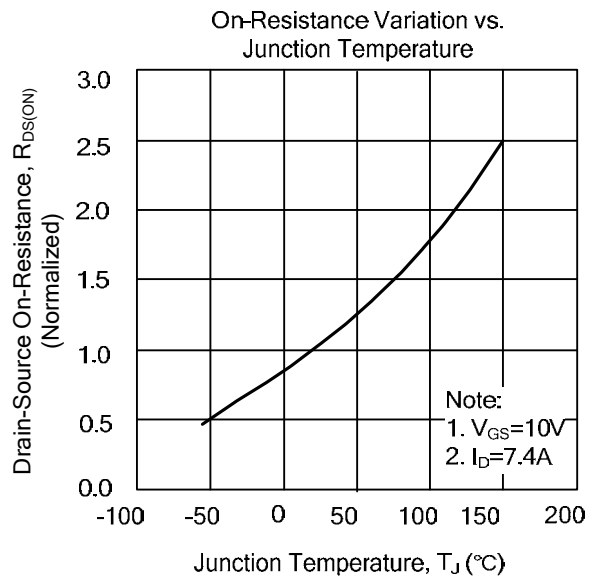
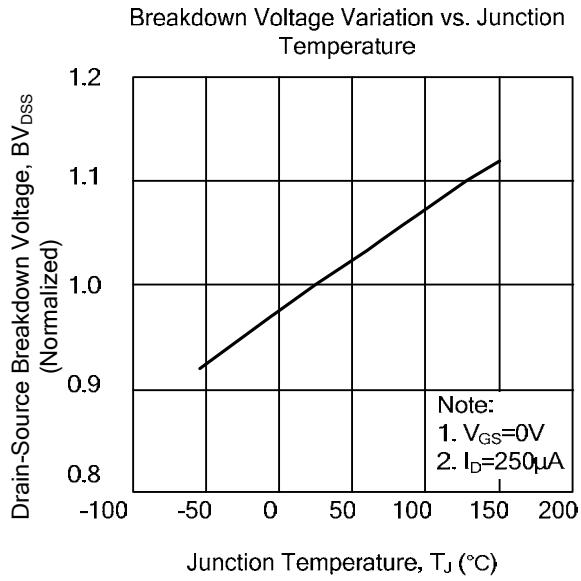

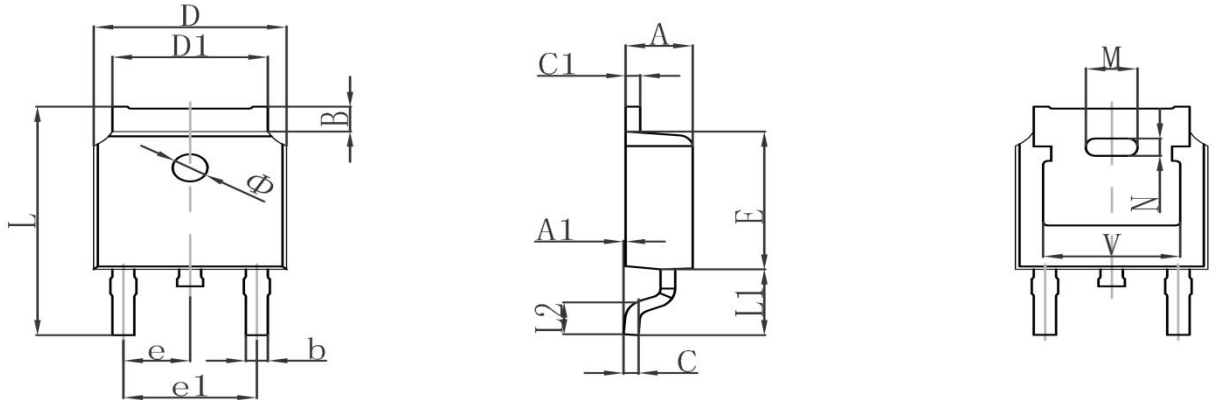
N-CHANNEL HIGH VOLTAGE MOSFET
TO-252 Package Outline Dimensions

Symbol	Dimensions In Millimeters		Dimensions In Inches	
	Min.	Max.	Min.	Max.
A	2.200	2.380	0.087	0.094
A1	0.000	0.100	0.000	0.004
B	0.800	1.400	0.031	0.055
b	0.710	0.810	0.028	0.032
c	0.460	0.560	0.018	0.022
c1	0.460	0.560	0.018	0.022
D	6.500	6.700	0.256	0.264
D1	5.130	5.460	0.202	0.215
E	6.000	6.200	0.236	0.244
e	2.286TYP		0.090TYP	
e1	4.327	4.727	0.170	0.186
M	1.778REF		0.070REF	
N	0.762REF		0.018REF	
L	9.800	10.400	0.386	0.409
L1	2.9REF		0.114REF	
L2	1.400	1.700	0.055	0.067
V	4.830REF		0.190REF	
Φ	1.100	1.300	0.043	0.051

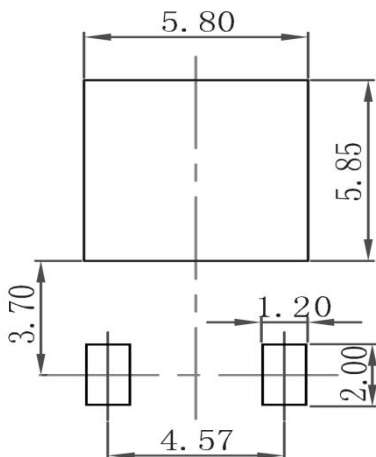
TO-252 Suggested Pad Layout

Note:

1. Controlling dimension: in millimeters
2. General tolerance: $\pm 0.05\text{mm}$
3. The pad layout is for reference purposes only

N-CHANNEL HIGH VOLTAGE MOSFET

TO-252 Tape and Reel

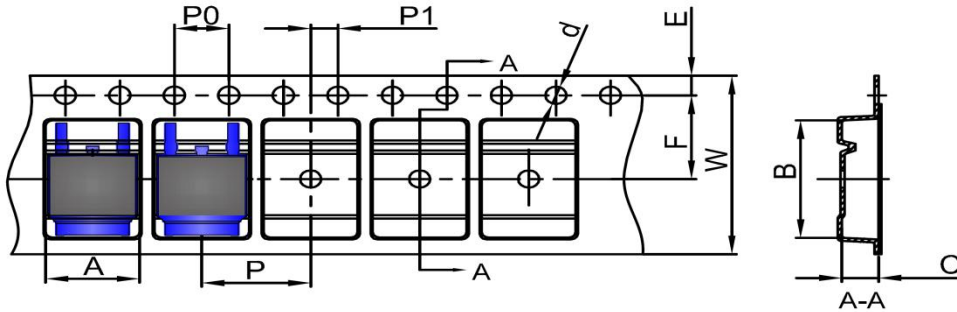
TO-252 Embossed Carrier Tape



DIMENSIONS ARE IN MILLIMETER										
TYPE	A	B	C	d	E	F	P0	P	P1	W
TO-252	6.90	10.50	2.70	Ø1.55	1.75	7.50	4.00	8.00	2.00	16.00
TOLERANCE	±0.1	±0.1	±0.1	±0.1	±0.1	±0.1	±0.1	±0.1	±0.1	±0.1

TO-252 Tape Leader and Trailer

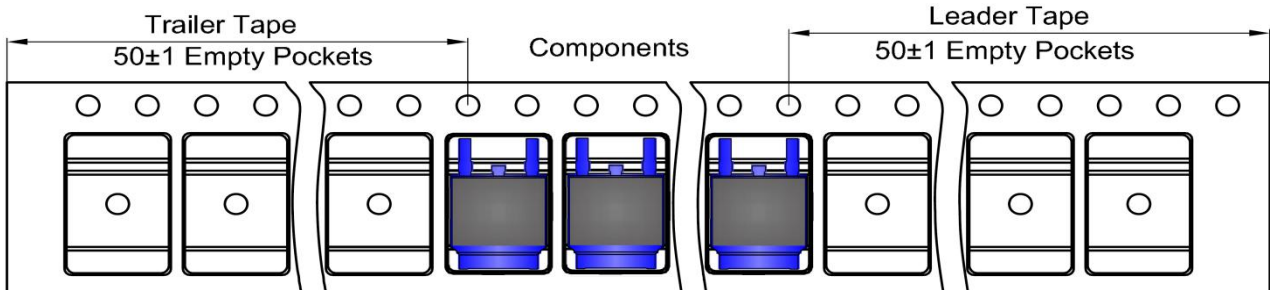

TO-252 Reel

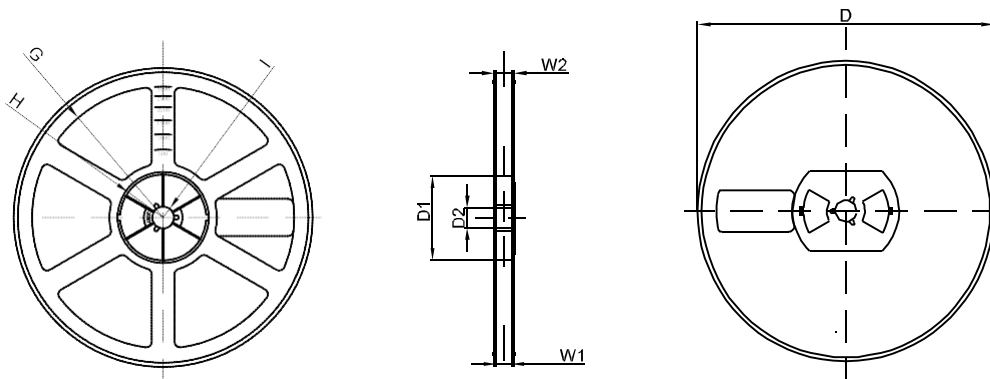

DIMENSIONS ARE IN MILLIMETER								
REEL OPTION	D	D1	D2	G	H	I	W1	W2
13" DIA	Ø330.00	100.00	Φ21.00	R151.00	R56.00	R6.50	16.40	21.00
TOLERANCE	±2	±1	±1	±1	±1	±1	±1	±1